

LESSON 2 - THE PINHOLE CAMERA

Overview:

In this lab activity, students will construct and use a pinhole camera to find the image of an object. Students will analyze their findings to determine how light travels in straight lines and how the human eye can be compared to a simple pinhole camera.

Suggested Timeline: 1.5 hours

Materials:

- The Pinhole Camera (Teacher Support Material)
- bright flashlight
- laser pointer
- two dusty chalk brushes
- The Pinhole Camera (Student Handout – Individual)
- The Pinhole Camera (Student Handout – Group)
- The following materials for the lab (1 per group of 2 students):
 - coffee can with translucent lid
 - 5 cm masking tape
 - 2 – 3 x 3 cm squares of coloured plastic (choose contrasting colours), taped side-side-by-side with clear tape
 - 40 W light bulb (non-frosted) in fixture – must be long bulb as is used in an aquarium
 - small nail (#2 finishing)
 - large nail (#8 common)

Method:

INDIVIDUAL FORMAT:

1. Have students complete their vocabulary list on the pinhole camera lab using the lab handout or other available resources. They should also read the background information before starting the lab.
2. Demonstrate the set up for the lab by showing students a pinhole camera that you have already made and how it will be used with the other materials in the lab to find the image.
3. Have students complete the lab activity and submit the lab handout for grading.

GROUP FORMAT:

1. Have students complete their vocabulary list on the pinhole camera lab using the lab handout or other available resources.
2. Introduce pinhole cameras by using the motivational set found on ‘The Pinhole Camera’ (Teacher Support Material).
3. Demonstrate the set up for the lab by showing students a pinhole camera that you have already made and how it will be used with the other materials in the lab to find the image.
4. Have students complete the lab activity and submit the lab handout for grading.

Assessment and Evaluation:

- Affective assessment of student ability to work in a lab group setting
- Student grade on lab

The Pinhole Camera

Motivational Set

Turn off the classroom lights. Turn on a bright flashlight. Ask students what they notice about the pathway of the light coming from the flashlight. (It travels in a straight line.)

Tell them that light always travels in straight lines when passing through a uniform medium (when the substance that it passes through, like air, does not change).

Ask them what other examples they can think of that give evidence that light travels in straight lines (automobile headlights, searchlights, the shadow cast by an object in the sun).

With the classroom lights still off, have a student shine a laser pointer toward the board (CAREFUL: NEVER TO POINT THE LASER AT STUDENTS' EYES). Have students note that the bright point of the laser can be easily seen on the board, but we still do not know for sure that the laser light travels in a straight line from the laser to the board. Bang two dusty chalk brushes along the pathway of the laser. The students will be able to see the straight pathway of the laser light!

Tell students that they are going to further investigate how light travels in straight lines by using a pinhole camera to make an image of an object. Modern cameras use glass or plastic lenses to make an image of the objects that they are focussed on, but the first cameras only used a simple pinhole, like the one that they will make today!

Answers to Lab Questions

Procedure and Observations:

6. Yes. The colours should be flipped upside down in the image as compared to the object.
7. a) Answers will vary
b) Yes, the image was reversed right to left.
8. The image gets smaller.

Analysis Questions:

1. The image of the tree should be sketched upside down.
2. The two sketches should follow the format of the sketch in #1, clearly showing the object further away and the image smaller in the second sketch.
3. Although the image does form on one's retina upside down, the brain flips the image right-side up.

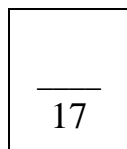

Name: _____ Date: _____ Period: _____

The Pinhole Camera



VOCABULARY: (4 x 1 mark each = 4 marks)

light ray –

image –

translucent –

orientation –

Background:

Think about shining a flashlight in a dark room or the bright beams of your car headlights. Both of these examples give evidence that light travels in straight lines if the substance or medium that it travels through does not change. In this lab activity, you will investigate this concept by making and using a pinhole camera.

Modern cameras use glass or plastic *lenses* to focus light from an object and form an image. The first cameras, however, only used a simple pinhole through which light passed. In both cases, one can trace the pathway that the light takes from the object, through the camera, to the spot where the image forms. Time to make a homemade camera!

Objective:

To discover how light rays travel and how a basic image is formed by using a homemade pinhole camera

Materials:

- large coffee can with a translucent cover
- 5 cm masking tape
- 2 – 3 x 3 cm squares of coloured plastic (choose contrasting colours), taped side-side-by-side with clear tape
- 40 W light bulb (non-frosted) in fixture – long aquarium-type bulb
- small nail (#2 finishing)
- large nail (#8 common)

Procedure and Observations:

1. Carefully punch two holes at either end of the metal end of the coffee can – one with the small nail and one with the larger nail (note Figure 1 below).
2. Place the masking tape over the larger hole.

3. Ensure that the translucent top is on the other end of the coffee can.
4. Turn on the 40 W bulb. Have a partner hold the coloured plastic squares in front of the bulb so that one colour is on top and the other is below.
5. Turn off the room lights.
6. Point the hole at the light and notice the pattern (image) formed on the translucent cover of the can. Is there any change in the position of the coloured plastic pieces when viewed through the camera vs. viewed with the naked eye? _____ If so, describe what change took place. _____

3

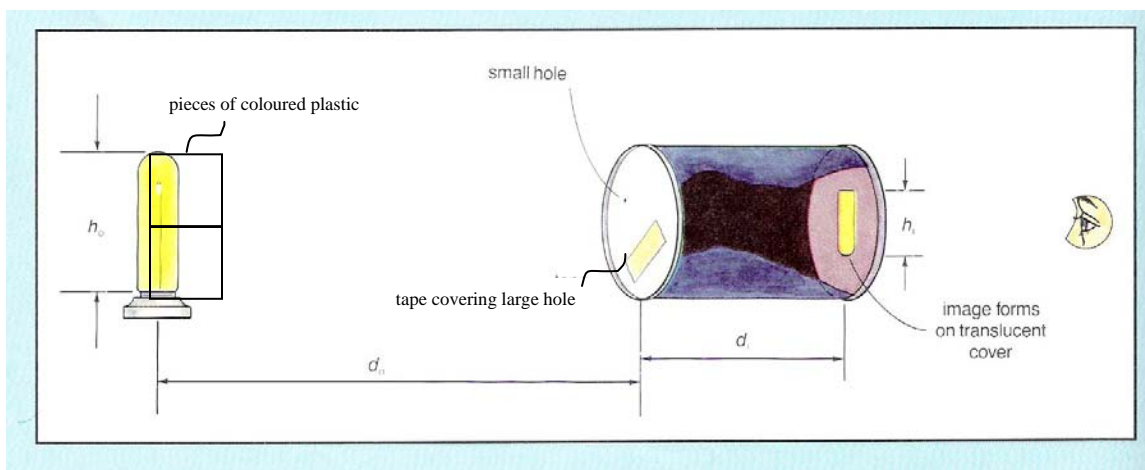

Figure 1: Pinhole Camera Experimental Set-Up

7. Design an activity to find out if the image is reversed right to left.

a) Describe what you did to find the answer. _____

2

b) Was the image reversed right to left as compared to the object? _____

1

8. Move the can farther from the bulb. How does the image change? _____

2

Analysis Questions:

1. Recall how the image was changed as compared to the object when viewed through the pinhole camera. The diagram below shows two rays of light starting at the object (a tree). Sketch in the image of the tree. (Hint: Is it right-side up or upside down?)

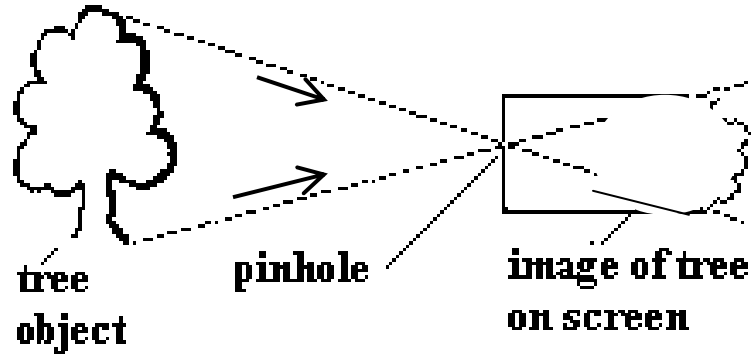

1

2. Make a series of two drawings to show why the image of the tree, as viewed through a pinhole camera, would get smaller as the camera is moved away from the object.

2

3. Your eye is a form of a pinhole camera. Why do you not see the images of things in your view upside down? (You may have to research this one!)

2

17

Name: _____ Date: _____ Period: _____

The Pinhole Camera



VOCABULARY: (4 x 1 mark each = 4 marks)

light ray –

image –

translucent –

orientation –

Objective:

To discover how light rays travel and how a basic image is formed by using a homemade pinhole camera

Materials:

- large coffee can with a translucent cover
- 5 cm masking tape
- 2 – 3 x 3 cm squares of coloured plastic (choose contrasting colours), taped side-side-by-side with clear tape
- 40 W light bulb (non-frosted) in fixture – long aquarium-type bulb
- small nail (#2 finishing)
- large nail (#8 common)

Procedure and Observations:

1. Carefully punch two holes at either end of the metal end of the coffee can – one with the small nail and one with the larger nail (note Figure 1 below).
2. Place the masking tape over the larger hole.
3. Ensure that the translucent top is on the other end of the coffee can.
4. Turn on the 40 W bulb. Have a partner hold the coloured plastic squares in front of the bulb so that one colour is on top and the other is below.
5. Turn off the room lights.
6. Point the hole at the light and notice the pattern (image) formed on the translucent cover of the can. Is there any change in the position of the coloured plastic pieces when viewed? If so, describe what change took place. _____

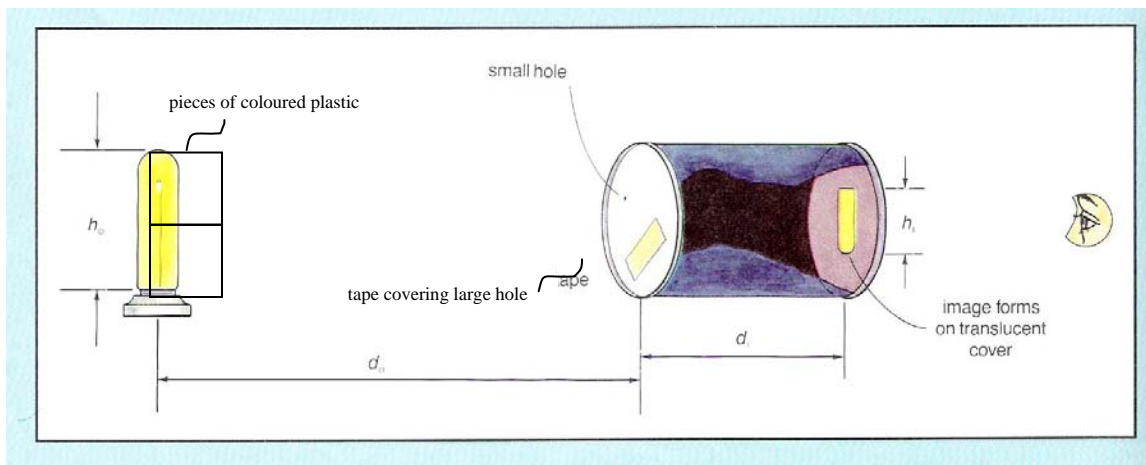

Figure 1: Pinhole Camera Experimental Set-Up

7. Design an activity to find out if the image is reversed right to left.

a) Describe what you did to find the answer. _____

2

b) Was the image reversed right to left as compared to the object? _____

1

8. Move the can farther from the bulb. How does the image change? _____

2

Analysis Questions:

1. Recall how the image was changed as compared to the object when viewed through the pinhole camera. The diagram below shows two rays of light starting at the object (a tree). Sketch in the image of the tree. (Hint: Is it right-side up or upside down?)

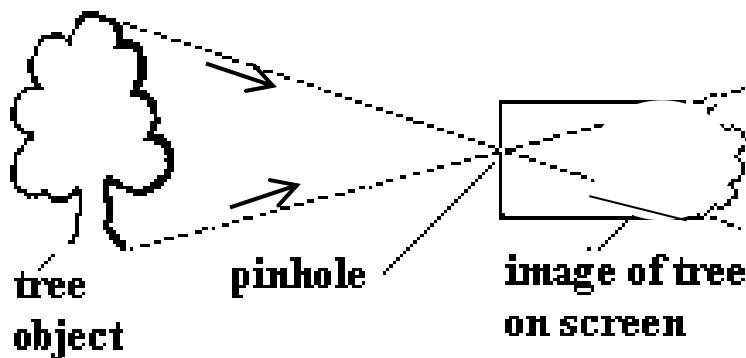

1

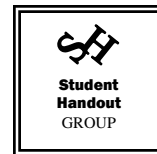

2. Make a series of two drawings to show why the image of the tree, as viewed through a pinhole camera, would get smaller as the camera is moved away from the object.

<hr/>
2

3. Your eye is a form of a pinhole camera. Why do you not see the images of things in your view upside down? (You may have to research this one!)

<hr/>
2